

IMPORTANT INSTALLATION INSTRUCTIONS
READ AND FOLLOW ALL INSTRUCTIONS
SAVE THESE INSTRUCTIONS

Seabrook™ 306059 Subway Tile Wall (HDCST306059xx)

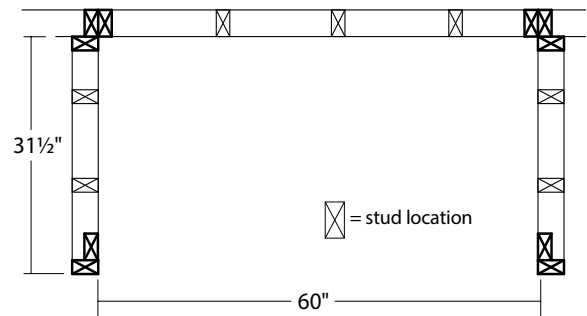
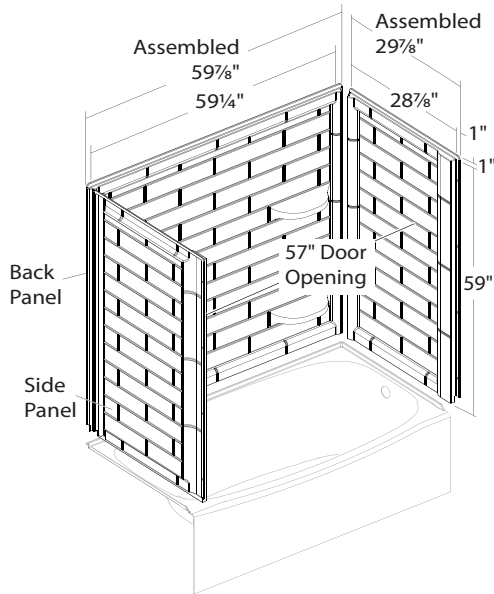

3060 SUGGESTED STUD LAYOUT. The Seabrook™ Subway Tile Bathtub Wall Set will fit most standard 30" x 60" bathtubs. **IMPORTANT: Studs highlighted in bold are required for proper installation.**

TOOLS YOU WILL NEED:

- Tape Measure
- Level
- Drill
- Pencil
- Safety Glasses
- Caulk Gun
- Appropriate Hole or Saber Saw (for Faucet Installation)

SUPPLIES YOU WILL NEED:

- 2 Tubes of Adhesive Compatible with Polystyrene Caulk (for Faucet Installation)
- Screws (Flathead Stainless)
- 2" Masking Tape
- Wood Shims

IMPORTANT

- Read installation instructions carefully before starting project.
- Peel back protective film to verify color before installation.
- Allow walls to reach room temperature before installation.
- Do not use plumber's putty. Will cause product failure and void warranty. Use a high grade silicone caulk for all necessary locations.
- Keep instructions for warranty information.

STEP 1. PREPARING ALCOVE

- Strip alcove to bare studs.
- Stud pocket should be constructed as shown above. Studs should be plumb and square to sub-floor.
- Check that there are no screws, nails or staples in the studs that will interfere with installation.
- If installing over existing bathtub/seated base check that studs are plumb to the bathtub and then go to step 3.
- For new construction place studs as shown on page 1.
- Check that the sub floor for the bathtub/seated base is level and studs are plumb to the sub floor. (Fig. 1)
- If desired add appropriate rated insulation between studs.

STEP 2. BATHTUB/SEATED BASE INSTALLATION

- Follow manufacturer's instructions for installing your bathtub/seated base.
IMPORTANT — Bathtub/seated base must be plumb and square to alcove for proper wall installation.

STEP 3. INSTALL SEAL STRIP

- Carefully separate (NOTE: PULL APART - DO NOT CUT) seal strip. (Fig. 2)
- Peel back protective film along both edges of back panel.
- Place seal strip along both sides of back panel removing protective paper as you apply. (Fig. 3)
IMPORTANT - DO NOT STRETCH SEAL STRIP!
- Apply pressure along the entire length of each strip to activate adhesive. Trim any excess seal.

NOTE: Failure to install seal strip will cause water damage and void warranty.

If seal strip is missing, please contact customer support before installing wall set.

STEP 4. TRIAL FITTING PANELS

- All panels must fully contact required studs as shown on page 1. (Fig. 4)
- Place back panel then fit side panels into place. (Fig. 5)
- Center wall on bathtub/seated base. Make sure panels rest flat on bathtub/seated base.
- If necessary, shim between panels and studs to provide a tight fit between the back and side panels. (Fig. 6)
- Align the front of the side walls to the front of the bathtub/seated base. This makes drywall installation easier.
- Mark height of wall on each stud to indicate where to apply adhesive on the stud. (Fig. 7)
- Measure and mark all control holes. After removing side panels, drill or saw necessary holes.
IMPORTANT — Drill or saw holes from front side. Cover area to be cut with masking tape to prevent chipping and scratching.

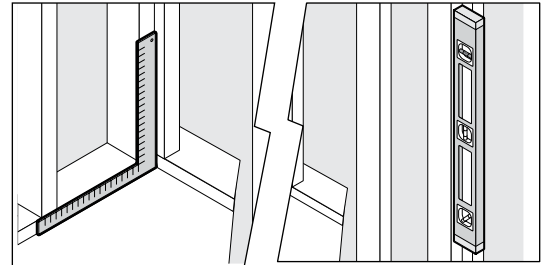

FIGURE 1. Check that studs are plumb with floor/shower.

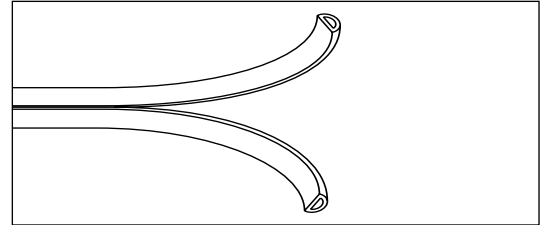

FIGURE 2. Carefully separate seal strip.

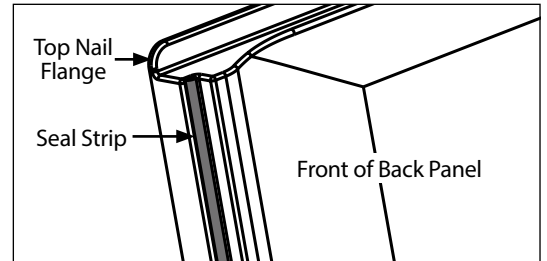

FIGURE 3. Place seal strip on both sides of back panel.

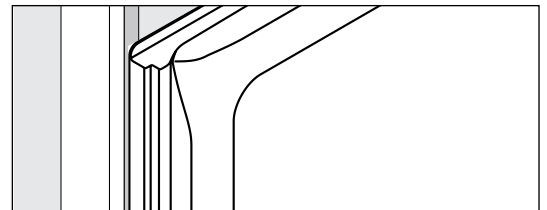

FIGURE 4. All panels must fully contact required studs.

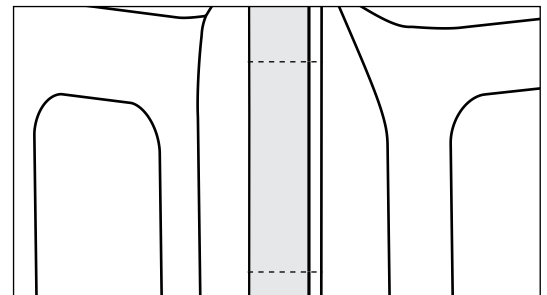

FIGURE 5. Fit side panels into place on back wall panel.

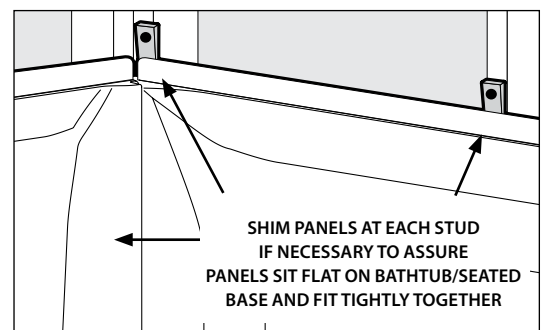

FIGURE 6. You can shim against the stud.

STEP 5. INSTALLING SHOWER WALL IN ALCOVE

- Peel back protective film along bottom edge of back and side panels.
- Apply a generous bead of adhesive below mark on each back panel studs only (follow adhesive manufacturer's recommended instructions) and install back panel.
- Apply adhesive to studs for side panel opposite the shower controls and install side panel.
- Apply adhesive to studs for faucet side panel and install side panel. (Fig. 8)
- Center wall on bathtub/seated base. Make sure panels are resting flat on bathtub/seated base.
- Reposition shims as needed.
- Press back panel firmly into place and align the front of the side walls to the front of the bathtub/seated base and screw back panel nail flange to studs.
- Apply pressure to one side panel, directing the pressure towards back panel, then screw vertical nail flange to stud. Repeat for opposite side panel.
- Screw top flange of side panels to studs.
- Apply pressure to panels while adhesive dries with cross bracing (Fig. 9). Panels must be held tight to studs during drying process.

IMPORTANT - Failure to screw all flanges to all studs will void warranty.

STEP 6. CAULKING

- For best results always use a high-grade silicone caulk.
- When installed on any Seasons bathtub/seated base your Seabrook™ wall is designed to function properly without seams being caulked.
- If you prefer the appearance of caulked seams, caulk all seams or leaks may occur.
- Caulk must be applied around holes for the faucet, diverter valve and shower head.
- If your Seabrook™ wall is used on a bathtub/seated base other than a Seasons, it is required to caulk all seams.
- If a shower door is installed, caulk is required between the bathtub/seated base, wall, and door.

STEP 7. FINISHING

Green Board or Other Finishing Boards

- Shim studs with lattice strips or 1/4" luan so that finishing board will overlap nail flanges. If your wall extends past the shown alcove, it may be necessary to shim these studs. (Fig. 10)

Tile

- Install finishing board up to (not over) nail flanges.
- Install tile over finishing board and nail flanges.

CLEANING

- Do not use any abrasive cleaners or metal scrapers.
- If drywall mud or plaster gets on a finished surface it may be carefully removed with a wooden scraper made from a piece of scrap wood.
- Adhesive may be removed with mineral spirits.
- Ideal cleaners are Soft Scrub Gel®, Comet Gel® or 409®.

WARNING: Some cleaning products are not suitable for use. Read all labels carefully. DO NOT USE if they say "not suitable for use with ABS, acrylic or polystyrene".

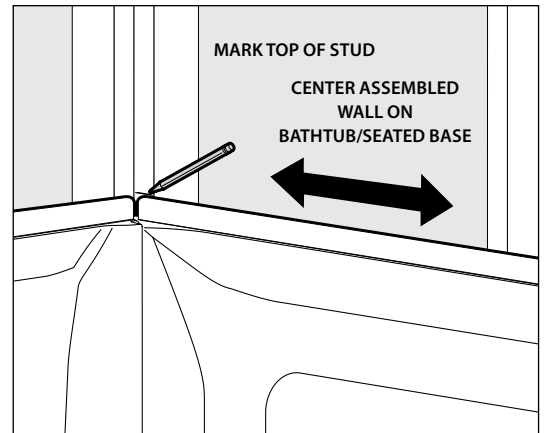

FIGURE 7. Mark studs.

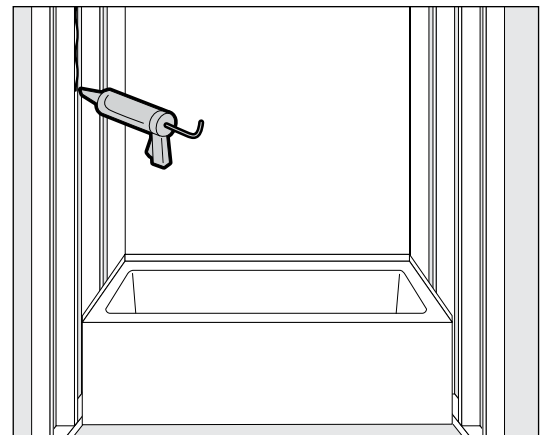

FIGURE 8. Apply adhesive.

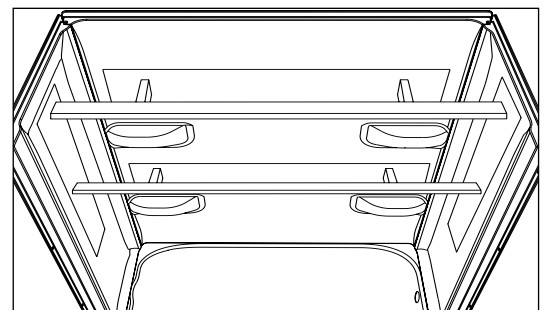

FIGURE 9. Apply pressure by cross bracing left and right panels while also applying pressure to the back panel.

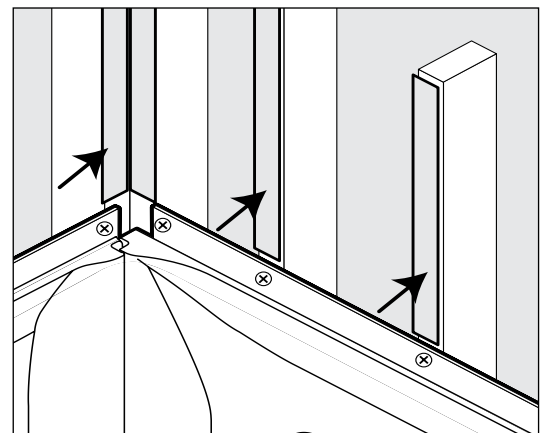

FIGURE 10. Shim studs.

HD SUPPLY BATHING FIXTURE — LIMITED WARRANTY 5-YEAR CONSUMER, 2-YEAR COMMERCIAL

HD Supply warrants to the original purchaser that this HD Supply bathing fixture will be free of manufacturing defects, which affect its performance as a bathing or showering fixture, under the following conditions and subject to the limitations contained in the "Remedies" and "Warranty Limitations" sections. The Limited Warranty applies for 5 years from the date of purchase if the fixture is used in a residential owner-occupied building for non-commercial purposes; or for 2 years from the date of purchase if it is used in any other building, including any building used for rental, commercial, or business purposes. This Limited Warranty is void if the fixture is not installed in accordance with the installation instructions supplied by HD Supply, or local building codes and ordinances, or if the care and cleaning instructions supplied by HD Supply are not followed. This Limited Warranty is also void if the fixture is moved from the location of its initial installation, or is subjected to accident, abuse, or misuse. The Limited Warranty excludes normal wear and tear, and does not cover damage that can be repaired by following the Scratch Removal Instructions. This Limited Warranty shall be void unless any failure or non-conformance is discovered before the expiration of this warranty, and is reported to HD Supply, in writing, accompanied by the original proof of purchase, within 30 days of discovery, to: **HD Supply Facilities Maintenance, Ltd., 10641 Scripps Summit Court, San Diego, CA 92131**

REMEDIES — The original purchaser's remedy under this Limited Warranty is limited to the repair, replacement, or refund of the purchase price of the fixture, at HD Supply sole option, of any part of the fixture which has failed or does not conform to the manufacturer's specifications. In no event shall HD Supply be liable for lost profits, loss of use, incidental, special or consequential damages including, but not limited to, damage to or loss of use of the building or its contents, arising out of any defect in the fixture; nor shall HD Supply be liable for any amount in excess of the original purchase price of the fixture. HD Supply reserves the right to require the return, at purchaser's expense, of the damaged fixture for repair or exchange before providing services under this Limited Warranty. If HD Supply elects to replace the fixture, its obligation is limited to supplying a replacement unit or component part of comparable size and style, and does not include the cost of removal, installation, or transportation, which must be borne by the purchaser. Replacement parts provided under this Limited Warranty are warranted for the remainder of the original warranty period applicable to the fixture, as if such parts were original components of that fixture.

WARRANTY LIMITATIONS — THERE ARE NO WARRANTIES WHICH EXTEND BEYOND THE DESCRIPTION ON THE FACE HEREOF. IMPLIED WARRANTIES, INCLUDING THOSE OF MERCHANTABILITY OR FITNESS FOR A PARTICULAR PURPOSE, ARE EXPRESSLY DISCLAIMED. HD SUPPLY DISCLAIMS ANY AND ALL LIABILITY FOR SPECIAL, INCIDENTAL OR CONSEQUENTIAL DAMAGES. Some states do not allow limitations of incidental or consequential damages, so the above limitations and exclusions may not apply to you. In such states, HD Supply's liability shall be limited to the extent permitted by state law. ANY IMPLIED WARRANTIES ARISING BY WAY OF STATE LAW, INCLUDING ANY IMPLIED WARRANTY OF MERCHANTABILITY OR ANY IMPLIED WARRANTY OF FITNESS FOR A PARTICULAR PURPOSE, ARE LIMITED IN DURATION AND IN SCOPE OF COVERAGE TO THE TERMS OF THIS LIMITED WARRANTY, UNLESS A SHORTER PERIOD IS ALLOWED BY LAW.

SCRATCH REMOVAL INSTRUCTIONS

- For effective scratch removal and polishing, you will need to purchase these items.
 - 1 sheet 1000 grit 3M® wet-dry sandpaper
 - 1 sheet 1500 grit 3M® wet-dry sandpaper
 - 1 sheet 2000 grit 3M® wet-dry sandpaper
 - 1 small container of 3M® rubbing compound #05933
 These items can be purchased at most auto supply stores that provide supplies to professional paint and body shops. Call before you go. Not all auto supply stores will have these items.
- Start sanding with 2000 grit paper. Use small squares of paper about 2" x 2" for all sanding, and use lots of water. The water serves as both a lubricant and to prevent residue buildup on the paper. Residue buildup shortens the effective life of the paper and may scratch the surface you're trying to polish.
- 2000 grit paper is the finest grit available (the higher the number, the finer the grit). If you can't remove all of the scratches with 2000 grit, switch to 1500 grit. Remember to wash the paper frequently with water as you sand.
- If all of the scratches can't be removed with 1500 grit, switch to 1000 grit. This should remove most fine scratches. If you have deep scratches or a gouge, coarser paper may have to be used (see chart to right). Be careful! Using grit that is too coarse may actually put in more scratches than it removes.
- Once you have removed all of the scratches, by sanding with the finest paper possible, repeat the sanding process using successively finer grits of paper until you've once again sanded with 2000 grit.
- Now use 3M® rubbing compound #05933 on a soft, damp cloth. Polish using considerable pressure to produce a smooth, shiny finish.

SUPERFICIAL SCRATCH
2000 grit

LIGHT SCRATCH
1500 – 2000 grit

MEDIUM SCRATCH
1000 – 2000 grit

DEEP GOUGE
600 – 2000 grit

SCRATCH / SANDPAPER GUIDE

HD Supply Facilities Maintenance, Ltd.

10641 Scripps Summit Court
San Diego, CA 92131
phone: (800) 431-3000

www.hdsupplysolutions.com